

PVHO Case 12
Use of Nonmetallic Braid Reinforced Flexible Membrane Vessels under PVHO-1

Approval Date: March 1, 2009

Inquiry: Under what conditions may portable nonmetallic braid reinforced flexible membrane hyperbaric stretchers and/or treatment systems be used in construction under the rules of PVHO-1?

Reply: It is the opinion of the Committee that portable nonmetallic braid reinforced flexible hyperbaric stretchers and/or treatment systems may be constructed under the requirements of PVHO-1 and be marked as a PVHO, when the requirements of PVHO-1, with the following exceptions and additions, have been met.

1 GENERAL

The Case covers a range of similarly designed and constructed PVHOs. The PVHOs may be of different shapes, sizes and have different pressure ratings depending upon their application. The parameters are limited to those listed below.

The flexible PVHOs shall each comprise a braided liquid crystal polymer (LCP) fiber tube [fig.1a] enclosing a pressure retaining membrane of impermeable polyurethane coated nylon [fig.1b]. The membrane is rigidly attached to a number of segmented aluminium clamp plates [fig.1c] at each end of the tube. The LCP fiber tube and coated nylon membrane are totally enclosed in a reinforced fire retardant polyurethane coated nylon outer cover [fig.1d] to protect the tubes from normal wear and tear, from ultraviolet exposure (sunlight) as well as for retaining the lifting straps in position.

The braided LCP tube also encloses two flexible LCP fiber rings [fig.1e], one at each end of the tube, outboard of the clamp plates. The flexible LCP fiber rings and the clamped membrane are sufficiently flexible to allow for the patient to enter and exit the PVHO, as well as for insertion and removal of the end closures. The end closures comprise acrylic spherical sector windows [fig.1f] set in nylon protection rings [fig.1g] that are suitably shaped to engage with the pressure retaining membrane. Services to the PVHO are provided through an aluminium penetrator plate, centrally positioned in one end closure. The other end may be fitted with a medical lock or with an additional penetrator plate.

The PVHOs shall be designed, constructed, inspected, tested, marked (and installed if applicable) to ASME PVHO-1, Sections 1, 2, 3, 4, 5 and 6 (as applicable), with exceptions and additions detailed in this Case.

All PVHOs shall fall within one of the following categories depending upon their size, number of occupants, maximum allowable working pressure (MAWP), service and gas outlets/BIBS

TABLE 1

Diameter Range in.	Max. number of Occupants	MAWP Range Psig	PVHO Service	Breathing Gas Outlets
23 - 30	One	33.5 to 75	Diving S6 and Medical S5	1
30 - 48	One	33.5	Diving S6 and Medical S5	1
36 - 48	Two	33.5	Diving S6 only	2

The following design and performance criteria shall also apply:

- (a) The maximum allowable working pressure (MAWP) shall not exceed 75 psig. (0.52 MPa).
- (b) The outside diameters of the PVHOs shall be between 23in. (58.5cm) and 48in. (122cm) .
- (c) The maximum length shall not exceed 120 in. (305 cm).
- (d) The vessel shall have removable end closures, incorporating windows.
- (e) The design number of pressure cycles shall not exceed 4000 cycles.
- (f) The life of the flexible tube and end closure assemblies shall be 10 years from the date of manufacture or on completion of the allowable number of pressure cycles stated in Section 6 Marking, whichever is achieved first.
- (g) The design operating temperature range shall be from 0°F to 100°F (-18°C to 38°C).
- (h) The design storage temperature shall range from -10°F to +150°F (-23°C to +66°C) using the storage cases supplied with the PVHO.
- (i) The pressurizing gas shall only be air and a label to this effect shall be suitably displayed.
- (j) The breathing gases, oxygen or air, shall be supplied to the occupant(s) of PVHOs through BIB masks or hoods. The operator shall select the breathing gas supply from the external control box. The operator shall also ensure that sufficient gases are available for flushing the PVHO if necessary, and have sufficient emergency gas supplies to complete the proposed treatment safely. All exhaled gases shall leave the PVHO via an overboard dump
- (k) All PVHOs shall have fire protection as specified in the relevant section of PVHO-1 (5 and 6)
- (l) All two (2) occupant PVHOs shall carry a hyperbaric fire extinguisher

A User's Design Specification shall be developed or provided for each model.

2 MATERIALS

Materials shall meet PVHO-1, para.1-6 PVHO Materials, with the exception of the flexible tube that shall conform to Table 2 below. All of the materials of the flexible tube shall be used in combination to meet the performance requirements of this Case. A process control procedure in accordance with 5.7 shall identify how the materials are to be used and in what specific quantities.

All materials used in the manufacture of the flexible tube shall be supplied with supporting documentation consistent with the requirements of the Quality Management System detailed in Section 5 of this Case. Each lot used in the manufacture of the flexible tube shall meet those properties listed.

Material shelf life shall be identified as being suitable for long term storage between uses and shall not exhibit visual or performance deterioration through aging, for the entire life of the PVHO. The PVHO shall be stored in cases that meet the sealing requirements of IP67 and DEFSTAN 81/41.

3 DESIGN AND MANUFACTURE

3.1 Design

The PVHO shall be designed in accordance with ASME PVHO-1, and this Case.

3.2 Requirements

In section 1-7, Design and Fabrication Requirements of PVHO-1, the design and manufacture of the PVHO shall only be in accordance with paras. 1.7.4 to 1.7.11 and the following requirements.

- (a) A detailed stress analysis shall be performed by a professional engineer registered in one or more U.S. states, or the provinces of Canada, or licensed by any other country that has equivalent licensing procedures and who is experienced in composite pressure vessel design and construction.
- (b) The stress analysis shall include full geometric modeling and a detailed finite element analysis of the PVHO and the flexible tube-to-window interface during assembly, disassembly, and under varying pressures up to a minimum of six times the maximum allowable working pressure (MAWP). The loads applied by lifting handles, straps and slings, as well as the position and weight of the occupants shall be considered.
- (c) The design analysis shall consider the effects of aging of the tube materials plus the effects of folding, unfolding, and long-term storage of its components. The design shall ensure that no damage will occur to any of the tube components by acute bending or by bending at less than the minimum bend radius for each component. Acute bending is defined as a bend in the LCP braid or the flexible membrane at an inside angle of less than 5 degrees. The minimum bend radius for the fiber or flexible membrane shall be no less than 0.05 in. (1.25mm).
- (d) There shall be no penetrations in the pressure retaining section of the flexible tube of the PVHO.
- (e) The design and manufacturing process shall produce a flexible tube such that the assembly will not be damaged by the assembly, pressurization, disassembly, or storage of the PVHO.
- (f) The maximum allowable working pressure (MAWP) shall be the lesser of 75psig or one sixth (1/6th) of the proof pressure test results.
- (g) The windows shall meet the requirements of PVHO-1, Section 2, Viewports, with the exception of para. 2-2.9, Viewport flanges. The design of the viewport flange shall be conducted as a part of the stress analysis requirement of para. 3.2(b) of this Case. The windows shall have standard window geometry (spherical sector with square edge) and qualify to meet the in-service guidelines of ASME PVHO-2.
- (h) The windows shall be fitted with a nylon protection ring secured to the windows with a retainer rigidly attached to the protection ring and sealed with an O-ring. The protection ring shall seal against the flexible membrane of the tube.
- (i) In lieu of the requirements of para. 4-9.6.1 of PVHO-1, the number of occupants will be defined by the number of breathing gas outlets supplied and as defined in the manufacturer's specification.
- (j) In lieu of the requirement of para. 6-3.1 (b) in PVHO-1, the minimum internal circumference of the flexible entry to the PVHO shall be 56 in. (142 cm), when the maximum overall diameter of the PVHO is less than 23.5 in. (600 mm).
- (k) All load bearing lifting handles, straps and slings shall be designed to meet the requirements of EN1492-1:2000 and be labeled. The number of occupants shall be taken into account.
- (l) Any changes to the design, materials or manufacturing procedures of the non-metallic components of the flexible tube shall be cause for prototype retesting.

3.3 Design Certification

Conformance of the design of the PVHO to the requirements of PVHO-1 shall be established by one of the two following procedures:

- (a) A professional engineer registered in one or more U.S. states, or the provinces of Canada, or licensed by any other country that has equivalent licensing procedures, and who is experienced in composite pressure vessel design shall certify that the PVHO was designed either by him or under his direct supervision, or that he has thoroughly reviewed a design prepared by others, and that to the best of his knowledge, the PVHO complies with PVHO-1 and this Case.
- (b) The design of the PVHO shall be reviewed by an independent third party agency experienced in both nonmetallic pressure vessel design and PVHO systems, and as such organization shall provide a certificate that the PVHO complies with PVHO-1 and this Case.

3.4 Manufacture

The tube shall be manufactured in accordance with a detailed process control plan.

The process control plan shall clearly define the details of the manufacturing steps necessary to fabricate the flexible tube, and shall document the fabrication process. Any anomalies found during the manufacturing process shall be fully documented and may be corrected according to the process control repair plan. Any production testing already completed, shall need to be repeated.

The materials and manufacturing processes used for production units shall be identical to those used for the tested prototypes.

4 TESTING

All prototype testing shall be witnessed by an independent third party certifying agency experienced in composite pressure vessel technology. In lieu of the testing requirements of PVHO-1, the following requirements shall apply.

4.1 Prototype Testing

(a) Pressure Proof Test

Hydrostatic proof tests shall be performed on a least three (3) completely assembled PVHOs of the same design, shape, and format at maximum operating temperature. Each PVHO shall be pressurized to six times design pressure and held without failure for a period of 30 minutes. Failure of the acrylic window assembly or the release of a window through the ends of the flexible tube shall be cause for failure of the prototype design. Should higher pressures be achieved, then the MAWP of the PVHO may be calculated using the applicable Statistical Analysis Method defined in Paragraph D-7 of the Non-Mandatory Appendix D. Regardless of test results, the MAWP defined in Section 1 (a) shall not be exceeded. The outer protective cover may be removed from the assembled PVHO for the pressure proof tests in order to visually record and identify the mode of failure.

(b) Drop Test

A drop test of at least one complete PVHO of each size on concrete shall be conducted without failure. The PVHO shall be fitted with end closures and loaded with 200 lb (90 kg) of bagged sand per occupant, and then pressurized to the MAWP. The PVHO shall be inclined at 45° and elevated to a height such that the minimum distance to the concrete impact surface is 3 ft (92cm) and then dropped. No leakage, damage, or permanent distortion of the PVHO is permissible.

(c) Cyclic Hydrostatic Test

A cyclic hydrostatic pressure test of each size of completely assembled PVHO shall be conducted for between 4,000 and 10,000 cycles. The test shall comprise pressurization from 2 psig (or less - but sufficient to ensure that the end closures remain sealed), to the MAWP and back to 2 psi at maximum operating temperature.

The duration of a cycle shall be determined by adding the times for the two tests described in a) and b) hereunder.

- 1) To establish the time for the pressure cycle, a hydrostatic test will be conducted on the PVHO to determine the time taken for pressurization from ambient pressure to MAWP, plus the time taken for any changes in volume, caused by stress settlement, to subside.
- 2) To establish the time for the depressurization cycle, a hydrostatic test will be conducted on the PVHO to determine the time taken for depressurization from MAWP to ambient pressure plus the time taken for any changes in volume, caused by stress relaxation to subside.

To establish the maximum number of cycles satisfactorily completed on the unit under test, the pressure retention properties of the vessel shall be checked every 2000 cycles for leakage or any damage to any component of the pressure retaining parts of the PVHO. Should leakage occur during cyclic testing, or at a cyclic level, then the maximum number of cycles achieved at the previous cyclic level shall be defined as [CT] and be used to determine the number of approved operational cycles [CA] for the PVHO using the following calculation:

$$CA = [CT/2] - 1000$$

(d) Extended Duration (Creep Rupture) Test

A fully assembled pressure retaining part of the PVHO shall be subjected to proof pressure testing at a pressure of five times the MAWP of the PVHO at maximum operating temperature for a period of at least 300 hours duration.

If at the completion of testing, the following criteria are met, the PVHO shall be considered to have acceptable creep behavior.

A straight line shall be plotted using semi log coordinates with pressure on the linear scale (Y) and time on the logarithmic scale (X). The beginning coordinate of the line shall be the pressure at 0.1 hour and the MAWP multiplied by 9. The end coordinate on the line shall be twice the MAWP at 80,000 hours. A straight line shall be drawn through these two coordinates. This line represents the minimum pressure-time acceptance line. Failure to the left and below the pressure-time acceptance line is disallowed.

(e) Cold Storage Test

A test shall be conducted at least twice, demonstrating that the pressure retaining part of the PVHO can be assembled and inflated at minimum operating temperature. The PVHO shall be folded and stored for a minimum of 8 hrs at minimum operating temperature immediately prior to the commencement of the tests.

(f) Offgassing Toxicity Test

An offgassing toxicity test shall be carried out that meets the requirements of Section 1-10 of ASME PVHO-1.

(g) Cyclic Folding Test

A folding and unfolding test shall be carried out on the flexible tube of the PVHO for a minimum of 4000 cycles. At the end of the test, the tube will be inspected to ensure that there is no damage, delaminations or other defects to any of the components of the flexible tube or cover.

(h) Puncture Test

A puncture test using a 3/8" wide flat screwdriver shall be performed on one PVHO at MAWP. The force to puncture the bladder shall be at least 225 lbs. After the screwdriver punctures the PVHO body, there shall be no tearing or rapid decompression.

Flexible tube and viewport components used in prototype testing above, shall not be used in production PVHO's.

4.2 Production Testing

Every completely assembled PVHO shall be subjected to a pneumatic test at a pressure of 1.5 times the MAWP and held for a period of 1 hr with a permissible leakage rate of 2% per hour. Internal and external air temperatures shall be measured and recorded at the beginning and end of each test so that compensation may be made for any temperature differences.

Every PVHO will be examined visually and dimensionally for damage following each test. Any signs of cracks, permanent deformation or other signs of damage will be grounds for rejection of the PVHO.

5 QUALITY ASSURANCE

5.1 General

PVHO's built to this Case shall be built by manufacturers whose Quality Management System is approved and certified by a Certified Body as meeting the requirements of ISO 13485:2003 and European Directive 93/42/EEC Annex II (excluding Section 4) for Medical Devices. In addition, the requirements of Section 3 of ASME PVHO-1 shall be met in full.

A documented Quality Assurance Plan (QAP) shall be developed for the design and manufacture of the PVHO. This section describes the requirements of the content of the QAP.

5.2 Organization

The QAP shall describe the organizational structure, with responsibilities, authorities, and lines of communication clearly delineated. Persons shown in the QAP to be responsible for verifying the PVHO quality shall have the authority and organizational freedom to

- (a) Identify problems affecting quality
- (b) Initiate, recommend or provide solutions to quality problems, through designated channels
- (c) Verify implementation of solution
- (d) Control further processing, delivery or assembly of a non-conforming item, deficiency or unsatisfactory condition until proper corrective action has been taken.

5.3 Design Control

A methodical process shall be used to develop and control the PVHO design, which includes:

- (a) A process for design inputs and review
- (b) A requirement for formal design review
- (c) A process for product configuration management and change control

5.4 Document Control

The QAP shall describe the manufacturer's measures for assuring that design output documents are correctly translated into manufacturing specifications, drawings, procedures and shop/lab instructions. Considerations shall be made for reviews and approvals, including those of the purchaser.

The manufacturer shall include the procedure for assuring distribution of appropriate documents to the working areas in a timely fashion and the process for assuring non-use of obsolete documents.

5.5 Procurement Control

The QAP shall include the controls necessary to assure that applicable requirements are included in procurement documents. The manufacturer shall describe the basis for source evaluation and selection and the method of objective evaluation of the quality of furnished materials, items and services upon receipt.

5.6 Material Control

The QAP shall describe the identification applied to material and items upon receipt and shall show that this identification shall remain until the material or item is incorporated into the PVHO. Identification shall be such that the manufacturer personnel can easily determine quality status, material or item type, specification, lot or part as appropriate and job number.

All material properties of production units shall meet or exceed the actual material properties of the prototype test articles.

5.7 Process Control

The QAP shall include a Process Control Procedure that will record the identification of materials and items incorporated into the PVHO and each chronological step in its manufacture, including inspection and test steps. The Process Control Procedure shall contain periodic operator and inspector signature points so that product status can be readily determined.

The manufacturer shall identify critical manufacturing activities and assure that they are accomplished by appropriately trained and qualified personnel. Inspection points shall follow the activities in the process control plan.

5.8 Inspection Control

The QAP shall include the measures used by the manufacturer to assure that inspections are reliable. These measures shall include:

- (a) Proper qualification of inspection personnel
- (b) Calibration of inspection instrumentation
- (c) Incorporation of acceptance criteria into inspection points in the Process Control Plan.
- (d) Assurance that inspections are performed by persons other than those performing or supervising work.
- (e) Documentation of all inspections.

5.9 Test Control

The QAP shall describe the measures used to assure that tests (including lab tests) are performed consistently and reliably. The following requirements shall be met:

- (a) Tests shall be performed in accordance with written instructions stipulating acceptance criteria.
- (b) Test results shall be documented.
- (c) Examination, measurement and testing equipment used for activities affecting quality shall be controlled, calibrated and adjusted at specified periods to maintain required accuracy.
- (d) Tests shall be performed by trained & qualified personnel.
- (e) Tests shall be verified by persons other than those performing or supervising the test.

5.10 Control of Measuring Test & Inspection Equipment

The QAP shall describe the equipment used in inspections and tests and the measures used to assure appropriate accuracy. Appropriate equipment shall be calibrated and the calibration shall be traceable to standards where they exist. Where such standards do not exist, the equipment manufacturer's recommendations shall be followed.

5.11 Control of Non-Conforming Items/Materials

The QAP shall describe the measures used by the manufacturer to control materials or items that are found to be discrepant to prevent their inadvertent use. Nonconforming materials/items shall be identified. The discrepant condition(s) shall be documented. The process for determining, documenting and verifying corrective action shall be described, including the involvement of the purchaser.

5.12 Quality Assurance Records

The QAP shall provide for quality assurance records:

- (a) Records shall be specified, compiled and maintained to furnish documentary evidence that services, materials and completed PVHOs meet this and applicable referenced standards
- (b) Records shall be legible, identifiable and retrievable.
- (c) Records shall be protected against damage, deterioration or loss.
- (d) Requirements and responsibilities for record transmittal, distribution, retention, maintenance and disposition shall be established and documented.
- (e) Records required for traceability shall be retained for a minimum of 12 years.

5.13 Standard Repair Planning

The QAP shall describe methods for repairing discrepancies that are expected to occur during the PVHO manufacture.

5.14 Quality Assurance Overview by an Independent Third Party

An independent third-party agency shall be employed to ensure that all PVHOs under this Case are designed and manufactured to the requirements of PVHO-1 and this Case. This includes, but is not restricted to the following:

- (a) The PVHO is designed in accordance with PVHO-1 and this Case

- (b) The manufacturer is working to the requirements of the quality control system.
- (c) The materials used in construction of the PVHO comply with approved procedures by qualified operators, as required by PVHO-1 and this Case.
- (d) All manufacturing operations are conducted in accordance with approved procedures by qualified operators, as required in PVHO-1 and this Case.
- (e) All defects are acceptably repaired.
- (f) All prototype and production testing has been performed and witnessed as required by PVHO-1 and this Case.
- (g) The PVHO is marked in accordance with PVHO-1 and this Case
- (h) A visual inspection of the PVHO is conducted to confirm that there are no material or dimensional defects.

The manufacturer shall arrange and give the third party inspection agency free access to all facilities associated with the manufacture of the PVHO. The manufacturer shall keep the third party inspection agency informed of the progress of the work and shall notify them reasonably in advance when PVHOs will be ready for any required tests or inspections.

TABLE 2

PVHO-1 Case 12 Structural Non-Metallic Materials of Construction - Pressure Tube			
Component	Material/Material Properties	Typical Values	Test Procedure or Specification
Membrane	Double Sided Aromatic Polyether Polyurethane Coated Nylon Fabric	Fabric: High tenacity 940 dtex polyamide Threads 11/cm Warp, 10/cm Weft Wt. 205 ±10 g/m ² Base nylon fabric to be scoured & heat set Coating/side: 0.2mm Total thickness: 0.70mm (nominal) Total weight: 0.73 kg/m ² Tensile strength: Warp min. 2850 N/5cm Weft min. 2400 N/5cm Tear strength: Warp min. 1600 N/5cm (chisel cut) Weft min. 1400 N/5cm Adhesion (min): 250 N/5cm Cold Resistance: - 30°C ±5	ISO 13934-1:1999 ISO 4674-1:2003
Braided Main Tube and End Ring	Liquid Crystal Polymer (LCP) Fiber Filament Yarn	1500 Denier 300 filaments/yarn Density: 1.4 g/cm ³ Tensile Strength [±10%]: 3.2 GPa, 25.9 g/denier, 465 ksi Tensile Modulus: 75GPa, 600g/denier, 10,760 ksi Equilibrium Moisture Regain < 0.1%	ASTM D885-07
Outer Cover & Braid End Fabric	PU coated woven polyester fabric cover and braid end fabric	Base fabric: Mass 180g/m ² Threads 17/cm warp, 13/cm weft. Coated Fabric: Total Mass 240 +/-10 g/m ² Tearing Strength: ≥75N Across Warp ≥85N Across Weft, Tensile Strength: ≥1800 N/50mm, Warp, ≥1200 N/50mm Weft	ISO 4674-1:2003 Method A2 ISO 13934-1
Handle Straps & Lifting Slings	Nylon Webbing with Stainless Steel Fittings	Structural items - not pressure boundary items	ISO 1492-1:2000

TABLE 3

Test Procedures and/or Specifications listed in Table 2 or referred to in Case 12	
ASTM D885-07	Standard test methods for tire cords, tire cord fabrics and industrial filament yarns made from man-made organic-base fibers.
ISO 1421:1998	Rubber or plastic coated fabrics for determination of tensile strength & elongation at break.
ISO 1492-1:2008	Textile slings. Safety. Flat woven webbing slings, made of man-made fibers for general purpose use.
ISO 4674-1:2003	Rubber or plastic coated fabrics. Determination of tear resistance - Part 1: Constant rate of tear methods.
ISO 13934-1:1999	Textiles. Tensile properties of fabrics. Determination of maximum force & elongation at maximum force using the strip method.
DEF STAN 81-41 Pt1 Issue6 including STANAG 4280	Ministry of Defence - Packaging of Defence Materiel
93/42/EEC	European Council Directive concerning Medical Devices

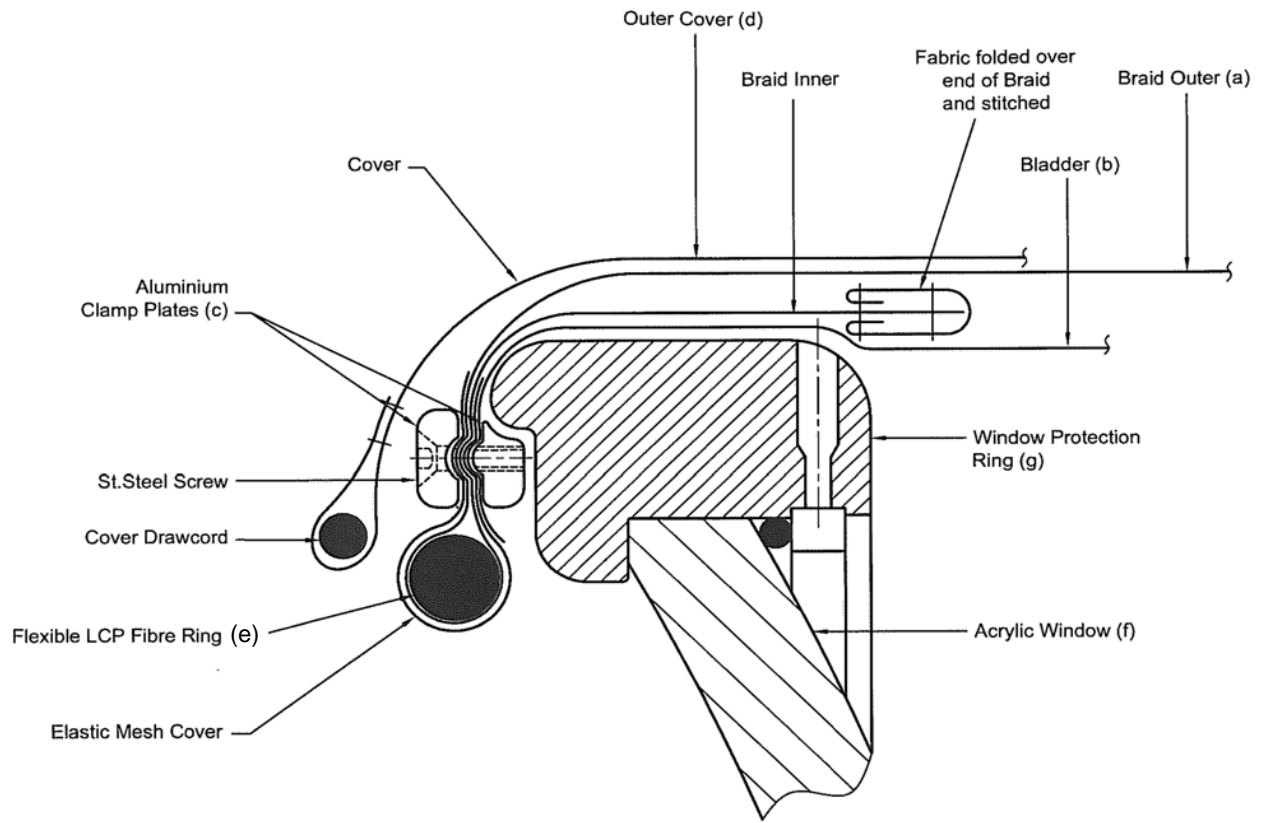
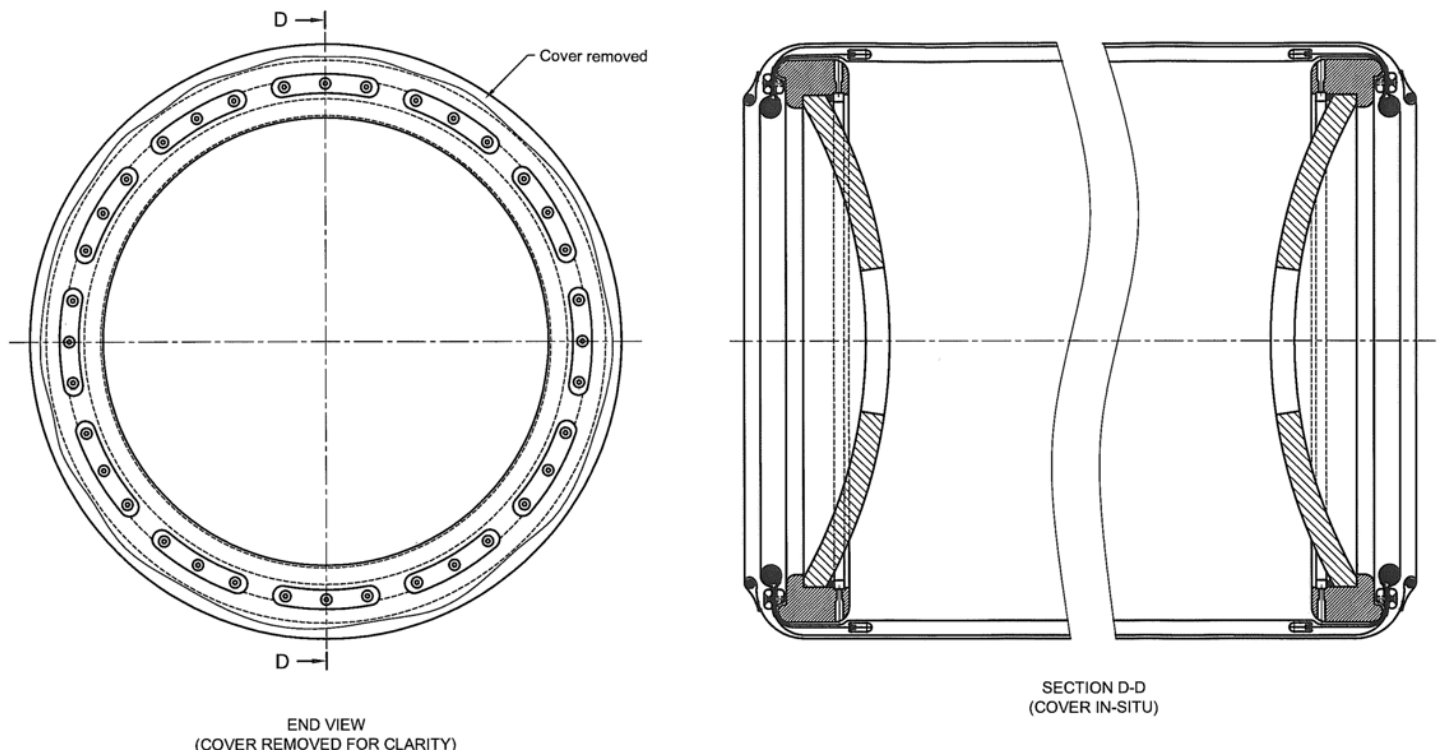

Figure 1.
DETAIL OF ASSEMBLY
(No Tension)



PVHO Case 12 Form Manufacturer's Data Report for Pressure Vessels for Human Occupancy

1. Design Criteria _____
2. Manufactured and certified by _____
3. Manufactured for _____
4. Vessel Identification _____
 _____ (Manufacturer's serial no.) _____ (year built)
5. The design, construction, workmanship, and chemical and physical properties of all parts meet the applicable material specifications of PVHO-1 _____ (year) and Case No_ 12 _____
6. Manufactured for a maximum allowable working pressure of _____ psig _____ barg _____ msw _____ fsw, a maximum working temperature of _____ °F _____ °C and a pneumatic internal test pressure of _____ psig _____ barg _____ msw _____ fsw
7. Design analysis conducted by _____
8. Designed for one occupant/one or two occupants (delete as applicable)
9. Windows: Certification Reports, properly identified and signed by the window fabricator, are attached for the following items:

Nos.	Location	Type	Diameter	Nominal Thickness	How attached

10 .Penetrator Plate No: _____ Penetrator Blank No: _____ Medlock No: _____

CERTIFICATION OF DESIGN	
User's Design Specification on file at _____	
Manufacturer Design Report on file at _____	
User's Design Specification certified by _____ State ____ Reg.no. _____	
Manufacturer's Design Specification certified by _____ State ____ Reg.no. _____	
Prototype test program attested by _____	
Quality Assurance Program reviewed by _____	
Manufacturer's documentation reviewed by _____	(name and date)
Production testing witnessed by _____	(name and date)
CERTIFICATE OF CONFORMITY	
We certify that the statements made in this report are correct and that all details of the design, material, construction and workmanship conform to the ASME Safety Standard for Pressure Vessels for Human Occupancy (PVHO-1) and PVHO Case 12	
Date _____	Company Name _____ Signed _____